

Servo SHORT BAR FEEDER with Program Memory

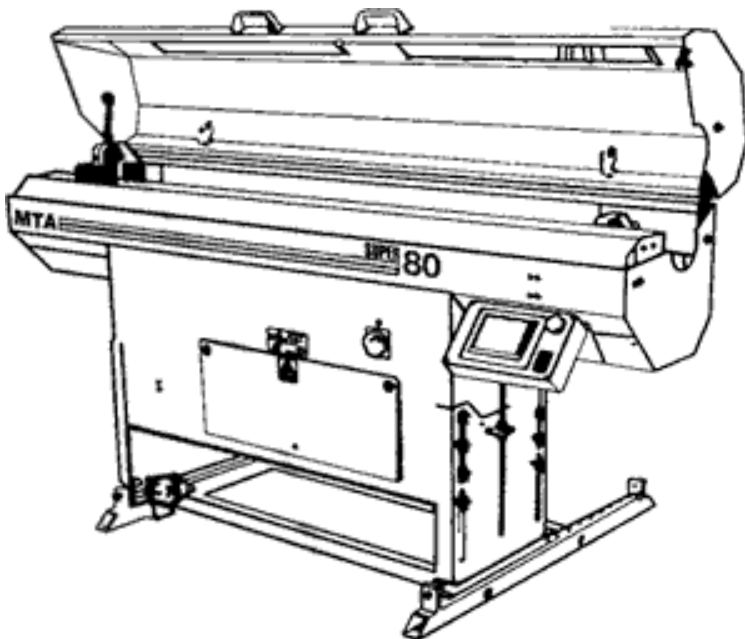

- Up to 100 DIFFERENT JOB SETTINGS in Bar Feed Memory to minimize re-occurring setup time
- Easy new job programming, modifications and past job look up
- Self adjusting barfeed with Automatic & programmable bar diameter height & thrust after material type input
- Accurate bar positioning, servo drive, belt fed, closed loop encoder
- Shock free presentation of material above feed rollers
- Material can be round, hexagonal, or square
- Material can be uniform or random in length
- Position to stop or dimension
- Sub spindle mode
- 'X' axis sliding rail standard
- Small 86" x 37" footprint
- 3 Pushers Standard
- 23.5" x 60" Material tray capacity (115 lineal feet of 1" material)



CAPACITY:

- Diameter 1/4" to 3 1/8"
- Length: Up to 60"

CAPACITY

BAR DIAMETER	Round Bar	1/4" - 3 1/8"
	Hexagonal	1/4" - 2 3/4"
BAR LENGTH	Max:	61"
BAR WEIGHT	Max:	180 lb
OPERATION	Bar Feeding	Servo Drive
		Guide Way Supported Belt Drive
	Bar Loading	Geared Motor
ACCURACY	First Infeed	±.020"
	Feeding	± .004"
PUSHERS	Standard (3)	5/16", 1/2", 11/16"
OPERATOR PANEL	Touch Screen Panel	

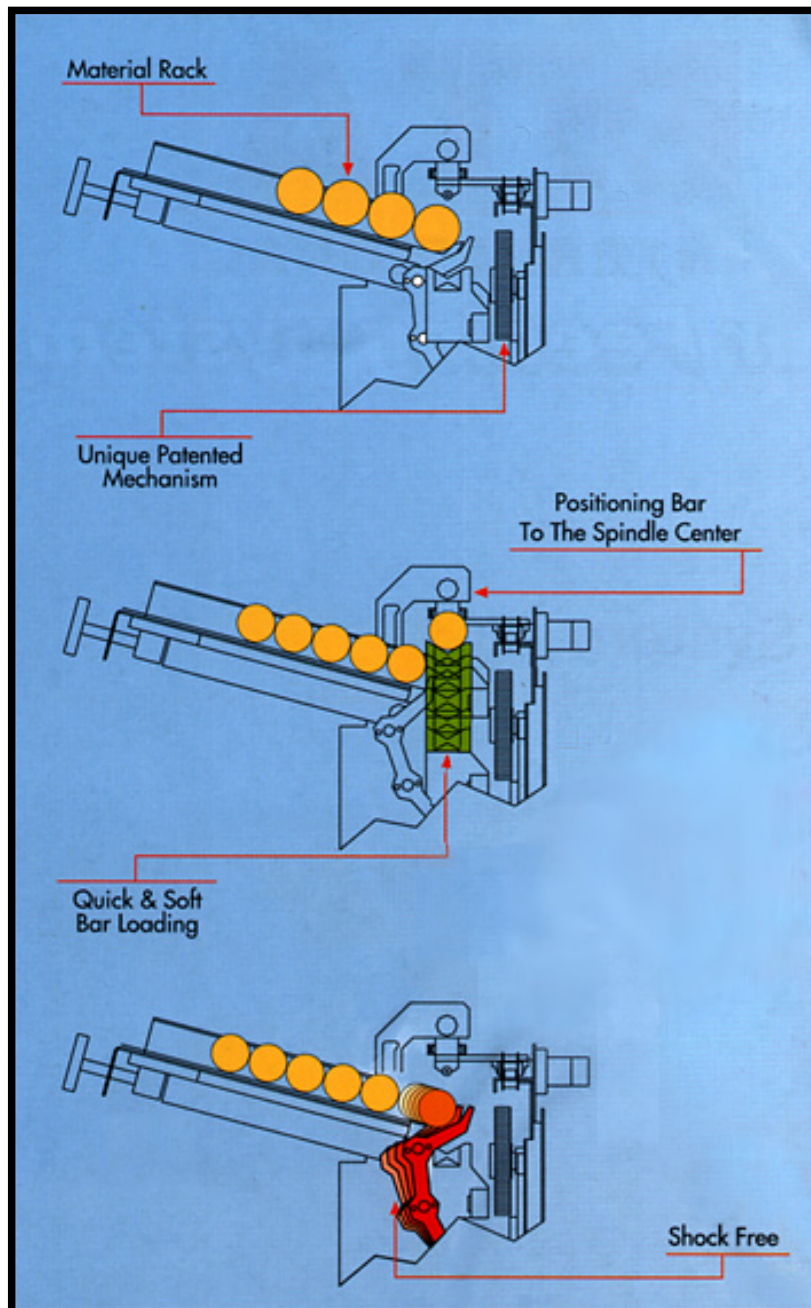

GENERAL DIMENSIONS

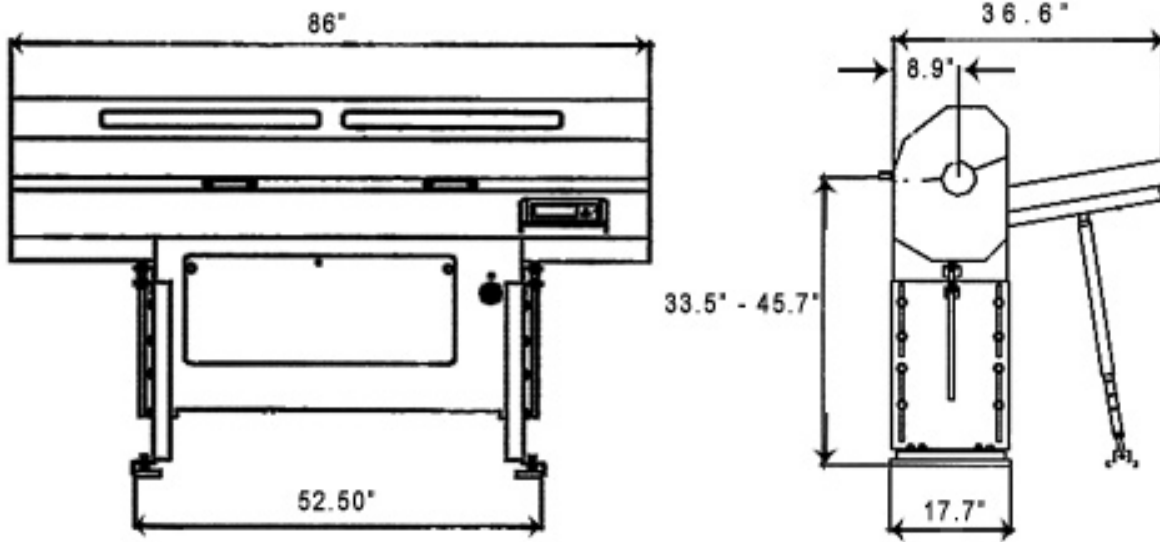

Tel: 513 772 4004
Fax: 513 772 4115
E-mail: sales@barfeeder.com

MTA INTERNATIONAL
11675 Chesterdale Rd
Cincinnati, OH 45246-3917

© MTA International, 2007